

Ariac trapani



Drills

Pick up any Atlas Copco drill...

It fits snugly in your hand. The anatomic design of the grip keeps the arm and wrist straight, reducing the risk of injury. The perfect balance of the tool enables you to guide it smoothly and easily. The high power-to-weight ratio means maximum stock removal in the shortest possible time. The chuck guard protects fingers, allowing a two-handed grip and comfortable guiding of the drilling operation.

Contents

Page

Selection guide.....	192
Pistol-grip drills	193
Micro stop drills.....	194
Straight drills.....	195
Angle drills	198
Tappers.....	202
Screw-feed drills	204

SELECTION GUIDE

Quality and ergonomics

The classic wing of the pistol-grip drill was designed more than 30 years ago. Its many ergonomic features still make it outstanding on the market in terms of user benefits.

Wide range of speed alternatives offers the right model for every application.

Rugged and reliable design offers low service and maintenance costs.

The rubber covered housing provides a comfortable soft grip. Prevents the tool from slipping in the hand and it improves the insulation.

The design and angle of the pistol grip keeps the wrist and arm straight due to better precision and less risk of injury.

Chuck guard allowing two-handed grip, as well as protecting fingers and chuck sleeve during drilling operation.

Unique, lubrication-free design for a cleaner working environment.

Easy, sensitive trigger action, with built-in throttling capability, reduces the risk of "trigger finger" symptoms.

Efficient silencing for a quieter working environment.

Exhaust discharge can be aimed away from the operator in any direction, eliminating the risk of airborne chips or dust whirling near the operator's face.

The hose is connected inside the handle which makes it possible to keep the coupling on the floor and to use the tool in cramped spaces. The "Flex connect" is only available to LBB16.

Choose the right drill for the right material

		Material/cutting speed					
Model		Mild steel 20-30 m/min	Alloy steel 5-15 m/min	Cast iron 15-20 m/min	Aluminium and bronze 50-80 m/min	Wood and board 80-150 m/min	Com- posite 50-100 m/min
LBB16 EP/EPX	200	—	—	—	1.0 - 2.0	1.0 - 4.0	1.0 - 4.0
	060	—	—	—	1.0 - 5.0	2.0 - 5.0	2.0 - 5.0
	045	1.0 - 2.5	—	1.0 - 2.0	2.0 - 8.0 ^a	4.0 - 10.0 ^a	4.0 - 10.0 ^a
	033	2.0 - 4.0	1.0 - 1.5	1.5 - 2.5	5.0 - 10.0 ^a	5.0 - 12.0 ^a	5.0 - 12.0 ^a
	024	2.5 - 5.0	1.0 - 2.0	2.0 - 4.0	—	—	—
	010	6.0 - 8.0	1.5 - 5.0	5.0 - 8.0	—	—	—
LBB34	H060	1.0 - 2.0	—	—	2.5 - 5.0	4.0 - 8.0	1.0 - 5.0
	H033	2.0 - 4.0	—	1.5 - 3.0	5.0 - 10.0	8.0 - 13.0 ^a	5.0 - 10.0
	H026	2.5 - 6.0	1.0 - 3.0	2.0 - 4.0	8.0 - 13.0 ^a	8.0 - 13.0 ^a	—
	H013	5.0 - 10.0	1.0 - 5.5	4.0 - 8.0	—	—	—
	H007	8.0 - 13.0	3.0 - 8.0	7.0 - 13.0	—	—	—
LBB36	H060	1.0 - 2.0	—	—	2.5 - 5.0	4.0 - 8.0	1.0 - 5.0
	H033	2.0 - 4.0	—	1.5 - 3.0	5.0 - 10.0	8.0 - 13.0	5.0 - 10.0
	H026	2.5 - 6.0	1.0 - 3.0	2.0 - 4.0	8.0 - 13.0 ^a	8.0 - 13.0 ^a	8.0 - 13.0 ^a
	H013	5.0 - 10.0	1.0 - 5.5	4.0 - 8.0	—	—	—
	H007	8.0 - 13.0	3.0 - 8.0	7.0 - 13.0	—	—	—
	H005	14.0 - 19.0 ^b	—	—	—	—	—
LBB45	H017	—	—	—	10.0 - 16.0	16.0 - 50.0 ^a	10.0 - 16.0
	H006	10.0 - 16.0	4.0 - 10.0	8.0 - 16.0	16.0 - 23.0 ^a	—	16.0 - 23.0 ^a
	H004	16.0 - 23.0 ^a	6.0 - 16.0	13.0 - 23.0 ^a	—	—	—

^a This bit size is larger than the standard chuck capacity of the machine.

^b To be used with No. 2 Morse socket adapter, see Optional Accessories.

DIMENSIONS LBB EP/EPX/H (mm)

Model	L	H	C	D	E	Model	L	H	C	D	E
						Model	L	H	C	D	E
LBB16 EP/EPX-200	177	131	16.5	31.4	13.8	LBB34 H013	238	156	23	41.5	50.0
LBB16 EP/EPX-060	177	131	16.5	31.4	13.8	LBB34 H007	238	156	23	41.5	50.0
LBB16 EP/EPX-045	177	131	16.5	31.4	13.8	LBB24 HF045	165	156	25	35.9	14.8
LBB16 EP/EPX-033	177	131	16.5	31.4	13.8	LBB24 HF020	165	156	25	35.9	14.8
LBB16 EP/EPX-024	177	131	16.5	31.4	13.8	LBB36 H060	217	157	23	41.5	16.5
LBB16 EP/EPX-020	177	131	16.5	31.4	13.8	LBB36 H033	217	157	23	41.5	16.5
LBB16 EP/EPX-010	190	131	16.5	31.4	27.0	LBB36 H026	217	157	23	41.5	16.5
LBB16 EP/EPX-005	190	131	16.5	31.4	27.0	LBB36 H013	256	157	23	41.5	64.0
LBB16 EP-003	190	131	16.5	31.4	27.0	LBB36 H007	256	157	23	41.5	64.0
LBB34 H060	199	156	23	41.5	16.5	LBB36 H005	256	157	23	41.5	64.0
LBB34 H033	199	156	23	41.5	16.5	LBB45 H006	360	185	33	60	113
LBB34 H026	199	156	23	41.5	16.5						

PISTOL-GRIP DRILLS

Atlas Copco pistol-grip drills are suitable for most drilling tasks in virtually every sector of industry.

- Comfortable grip for high precision.
- Cost-saving.
- Two-hand grip available.
- Lubrication-free.

The new LBB16 is the answer to market demands for:

- Improved ergonomics.
- Increased power.
- Smaller size.

LBB16 EP	290 W	(0.4 hp)^a
LBB16 EPX	340 W	(0.45 hp)^a
LBB34	400 W	(0.6 hp)^a
LBB36	700 W	(0.9 hp)^a
LBB45	700 W	(0.9 hp)^b

^a Lubrication-free motor.

^b Conventional motor (pistol-grip drill only).



Model	Free speed r/min	Chuck capacity mm	Weight		Air consumption at free speed		Hose size		Air inlet thread BSP	Sound level at free speed dB(A)	With chuck Ordering No.	Without chuck	
			kg	lb	l/s	cfm	mm	in				Model	Ordering No.
Non-reversible drills with air supply through handle													
LBB16 EP-200 ^a	20000	6.5	0.6	1.2	8.0	17.0	6.3	1/4	1/4	75	8421 0108 60*	200-U	8421 0108 61
LBB16 EP-060 ^a	6000	6.5	0.6	1.2	8.0	17.0	6.3	1/4	1/4	75	8421 0108 50*	060-U	8421 0108 51
LBB16 EP-045 ^a	4500	6.5	0.6	1.2	8.0	17.0	6.3	1/4	1/4	75	8421 0108 40*	045-U	8421 0108 41*
LBB16 EP-033 ^a	3300	6.5	0.6	1.2	8.0	17.0	6.3	1/4	1/4	75	8421 0108 30*	033-U	8421 0108 31*
LBB16 EP-024 ^a	2400	6.5	0.6	1.2	8.0	17.0	6.3	1/4	1/4	75	8421 0108 20*	024-U	8421 0108 21*
LBB16 EP-010	1000	10.0	0.7	1.5	8.0	17.0	6.3	1/4	1/4	75	8421 0108 10*	010-U	8421 0108 11*
LBB16 EP-005 ^b	500	10.0	0.7	1.5	8.0	17.0	6.3	1/4	1/4	75	8421 0108 06*	005-U	8421 0108 07*
LBB16 EP-003 ^b	300	10.0	0.7	1.5	8.0	17.0	6.3	1/4	1/4	75	8421 0108 01*	003-U	8421 0108 02
LBB16 EPX-200 ^a	20000	6.5	0.6	1.2	9.5	20.0	6.3	1/4	1/4	78	8421 0108 82*	200-U	8421 0108 63
LBB16 EPX-060 ^a	6000	6.5	0.6	1.2	9.5	20.0	6.3	1/4	1/4	78	8421 0108 52*	060-U	8421 0108 53*
LBB16 EPX-045 ^a	4500	6.5	0.6	1.2	9.5	20.0	6.3	1/4	1/4	78	8421 0108 42*	045-U	8421 0108 43*
LBB16 EPX-033 ^a	3300	6.5	0.6	1.2	9.5	20.0	6.3	1/4	1/4	78	8421 0108 32*	033-U	8421 0108 33*
LBB16 EPX-024 ^a	2400	6.5	0.6	1.2	9.5	20.0	6.3	1/4	1/4	78	8421 0108 22*	024-U	8421 0108 23*
LBB16 EPX-010 ^b	1000	10.0	0.7	1.5	9.5	20.0	6.3	1/4	1/4	78	8421 0108 12*	010-U	8421 0108 03*
LBB16 EPX-005 ^b	500	10.0	0.7	1.5	9.5	20.0	6.3	1/4	1/4	78	8421 0108 08*	050-U	8421 0108 09*
LBB34 H060 ^a	6000	10.0	1.1	2.4	9.5	20.0	10.0	3/8	1/4	77	8421 0308 47*	-H060U	8421 0308 96*
LBB34 H033 ^a	3300	10.0	1.1	2.4	9.5	20.0	10.0	3/8	1/4	77	8421 0308 39*	-H033U	8421 0308 88*
LBB34 H026 ^a	2600	10.0	1.1	2.4	9.5	20.0	10.0	3/8	1/4	77	8421 0308 21*	-H026U	8421 0308 70*
LBB34 H013 ^a	1300	10.0	1.5	3.3	9.5	20.0	10.0	3/8	1/4	77	8421 0308 13*	-H013U	8421 0308 62*
LBB34 H007 ^b	700	13.0	1.6	3.5	9.5	20.0	10.0	3/8	1/4	77	8421 0308 05*	-H007U	8421 0308 54*
LBB36 H200 ^a	20000	6.5	1.0	2.2	16.5	34.9	10.0	3/8	3/8	81	8421 0408 55	-H200U	8421 0408 53
LBB36 H060 ^a	6000	6.5	1.2	2.5	16.5	34.9	10.0	3/8	3/8	81	8421 0408 49*	-H060U	8421 0408 47*
LBB36 H033 ^a	3300	10.0	1.2	2.5	16.5	34.9	10.0	3/8	3/8	81	8421 0408 41*	-H033U	8421 0408 39*
LBB36 H026 ^a	2600	10.0	1.2	2.5	16.5	34.9	10.0	3/8	3/8	81	8421 0408 33*	-H026U	8421 0408 31*
LBB36 H013 ^a	1300	10.0	1.5	3.3	16.5	34.9	10.0	3/8	3/8	81	8421 0408 15*	-H013U	8421 0408 13*
LBB36 H007 ^b	700	13.0	1.6	3.5	16.5	34.9	10.0	3/8	3/8	81	8421 0408 07*	-H007U	8421 0408 05*
LBB36 H005 ^b	500	–	1.2	3.3	16.5	34.9	10.0	3/8	3/8	81	–	-H005U	8421 0408 03*
LBB45 H017 ^b	1700	16.0	4.2	9.3	10.0	21.0	10.0	3/8	1/4	85 ^c	8421 0501 32*	–	–
LBB45 H006 ^b	600	16.0	4.3	9.3	10.0	21.0	10.0	3/8	1/4	85 ^c	8421 0501 24*	–	–
LBB45 H004 ^b	400	16.0	4.3	9.3	10.0	21.0	10.0	3/8	1/4	85 ^c	8421 0501 16*	–	–
Reversible drills with drill chuck and quick change 1/4" bit holder													
COMBI24 HR36	3600	6.5	0.9	2.0	7.0	15.0	6.3	1/4	1/4	75	8431 0255 88	–	–
COMBI24 HR16	1600	10.0	0.9	2.0	7.0	15.0	6.3	1/4	1/4	75	8431 0255 79*	–	–
COMBI24 HR08	800	10.0	1.1	2.4	7.0	15.0	6.3	1/4	1/4	75	8431 0255 61	–	–
COMBI34 HR16	1600	10.0	1.0	2.2	8.0	17.0	10.0	3/8	1/4	79	8431 0311 36	–	–
COMBI34 HR08	800	10.0	1.3	2.9	8.0	17.0	10.0	3/8	1/4	79	8431 0311 34	–	–
COMBI34 HR04	400	13.0	1.5	3.3	8.0	17.0	10.0	3/8	1/4	79	8431 0311 32	–	–

^a Including chuck guard.

^b Including support handle.

^c 79 dB(A) with silencer set 4112 0863 80.

* Available directly from stock.

ACCESSORIES INCLUDED

Chuck, chuck key, hose nipple.

LBB16, 34 and -36 with suspension yoke and with chuck guard where possible.

16, 34 and -36-models have a 3/8" -24 UNF spindle thread LBB36 H005 has a 1/2" thread, LBB45 has a JT3 taper mount.

OPTIONAL ACCESSORIES

See page 196-197

MICRO STOP DRILLS

With integrated micro stop for higher accuracy

The LBS24 drill is equipped with an integrated micro stop intended for the aerospace industry where high precision drilling, reaming and countersinking is important.

- **Accurate** – The integrated micro stop function makes the LBS24 unique for high precision drilling of rivet holes and other fasteners. Minimized spindle run out is induced by eliminating standard drill chuck.
- **Ergonomic** – The handle is from our well-known Ergoline drills. The integrated micro stop function makes the tool shorter and lighter in weight.
- **Flexible** – Can be used for drilling, reaming, countersinking and in certain applications a combined operation using a form bit.
- **Dust extraction** – A specially designed spot suction is developed for working in composite.



- **Lubrication-free** – For clean working environment and operator comfort.

Model	Free speed r/min	Spindle thread in/mm	Stroke		Setting range ±		Weight		Hose size		Air consumption		Sound level dB(A)	Air inlet thread BSP	Ordering No.
			mm	in	mm	in	kg	lb	mm	in	l/s	cfm			
LBS24 H045-40M	4500	M6x1	40	1.6	6	1/4	1.1	2.4	6.3	1/4	5.9	12.5	74	1/4	8421 0220 10
LBS24 H045-40	4500	1/4"-28	40	1.6	6	1/4	1.1	2.4	6.3	1/4	5.9	12.5	74	1/4	8421 0220 30
LBS24 H010-40M	1000	M6x1	40	1.6	6	1/4	1.2	2.8	6.3	1/4	5.9	12.5	73	1/4	8421 0220 50
LBS24 H010-40	1000	1/4"-28	40	1.6	6	1/4	1.2	2.8	6.3	1/4	5.9	12.5	73	1/4	8421 0220 70
LBS36 H033-40	3300	1/4"-28	40	1.6	6	1/4	1.2	2.6	10	3/8	16.5	34.9	81	3/8	8421 0220 80
LBS36 H013-40	1300	1/4"-28	40	1.6	6	1/4	1.5	3.3	10	3/8	16.5	34.9	81	3/8	8421 0220 90

DIMENSIONS LBS H (mm)

Model	L	H	C
LBS24 H045-40M	247	154	20
LBS24 H045-40	247	154	20
LBS24 H010-40M	278	154	20
LBS24 H010-40	278	154	20
LBS36 H033-40	281	157	21
LBS36 H013-40	314	157	21

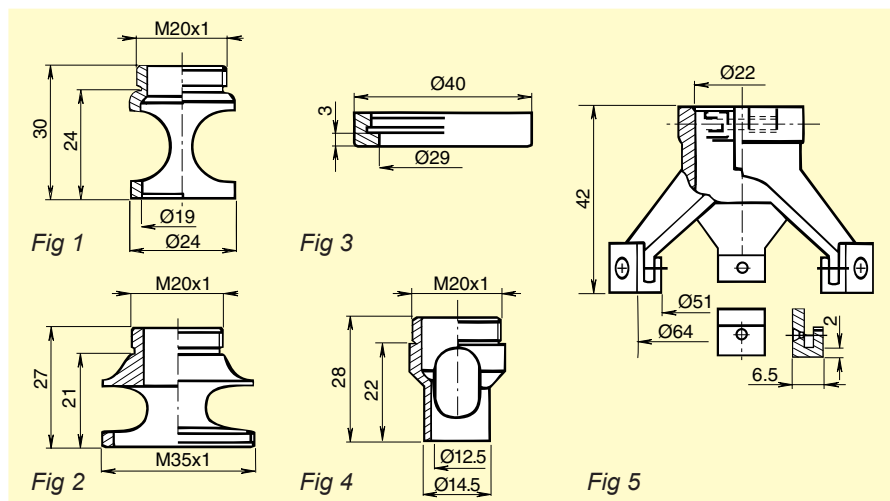
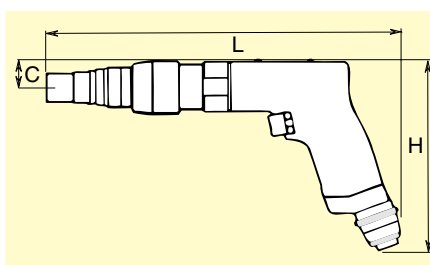

ACCESSORIES INCLUDED

- Hose nipple
- 2x2 mm Allen wrenches



SERVICE KIT
4081 0005 90

OPTIONAL ACCESSORIES

Designation	Attachment	Ordering No.
Plain base, dia 24 mm	Fig 1 M 20x1	4110 1521 00
Plain base for nylon ring (attached with thread M35x1)	Fig 2 M 20x1	4110 1522 00
Separate nylon ring for above base, outer dia 40 mm, thread M35x1	Fig 3 M 20x1	4110 1523 00
Plain base, dia 14.5 mm	Fig 4 M 20x1	4110 1520 00
Tripod, nylon supported	Fig 5 Dia 22 mm	4110 1524 00
Spot suction attachment for drilling in composite, to be used in combination with plain base, dia 24 mm	See photo above	4110 1529 90

STRAIGHT DRILLS

The straight drills are intended mainly for vertical drilling operations and for drilling in cramped and confined spaces.

- **Quiet** – They have a very low noise level, just like all our drills.
- **Side exhaust (LBB34)** – The air can be directed for operator convenience.
- **Rear exhaust (LBB24)** – The air is piped away through a pliant hose and prevents whirls of dust.
- **Lubrication-free** – 24- and 34-series of drills are lubrication-free for clean working environment and operator comfort.



LBB24 210 W (0.3 hp) Lubrication-free motor
LBB34 400 W (0.6 hp) Lubrication-free motor

Model	Free speed r/min	Chuck capacity mm	Weight		Air consumption at free speed		Hose size		Air inlet thread BSP	Sound level at free speed dB(A)	With chuck Ordering No.	Without chuck	
			kg	lb	l/s	cfm	mm	in				Model	Ordering No.
Drills with rear exhaust													
LBB24 S200B	19000	6.5	0.8	1.7	6.0	13.0	6.3	1/4	1/4	75	8421 0205 15*	-S200U	8421 0205 56
LBB24 S060B	6000	6.5	0.8	1.7	6.0	13.0	6.3	1/4	1/4	75	8421 0205 17*	-S060U	8421 0205 19*
LBB24 S045B	4500	6.5	0.8	1.7	6.0	13.0	6.3	1/4	1/4	75	8421 0205 23*	-S045U	8421 0205 64*
LBB24 S033B	3300	6.5	0.8	1.7	6.0	13.0	6.3	1/4	1/4	75	8421 0205 31*	-S033U	8421 0205 72*
LBB24 S020B	2000	6.5	0.8	1.7	6.0	13.0	6.3	1/4	1/4	75	8421 0205 49*	-S020U	8421 0205 80
Drills with side exhaust													
LBB34 S060	6000	10.0	1.1	2.4	10.0	21.0	10.0	3/8	1/4	88	8421 0309 41*	-S060U	8421 0309 74*
LBB34 S026	2600	10.0	1.1	2.4	10.0	21.0	10.0	3/8	1/4	88	8421 0309 25*	-S026U	8421 0309 82*
LBB34 S013	1300	10.0	1.5	3.3	10.0	21.0	10.0	3/8	1/4	87	8421 0309 17*	-S013U	8421 0309 90*

24- and 34-models have a 3/8" -24 UNF spindle thread.

* Available directly from stock.

DIMENSIONS LBB S (mm)

Model	L	H	C	D	E
LBB24 S200	183	38	19	35.9	14.8
LBB24 S060	198	38	19	35.9	14.8
LBB24 S045	183	38	19	35.9	14.8
LBB24 S033	183	38	19	35.9	14.8
LBB24 S020	183	38	19	35.9	14.8
LBB34 S060	192	43	21	41.5	16.5
LBB34 S026	192	43	21	41.5	16.5
LBB34 S013	200	43	21	41.5	16.5

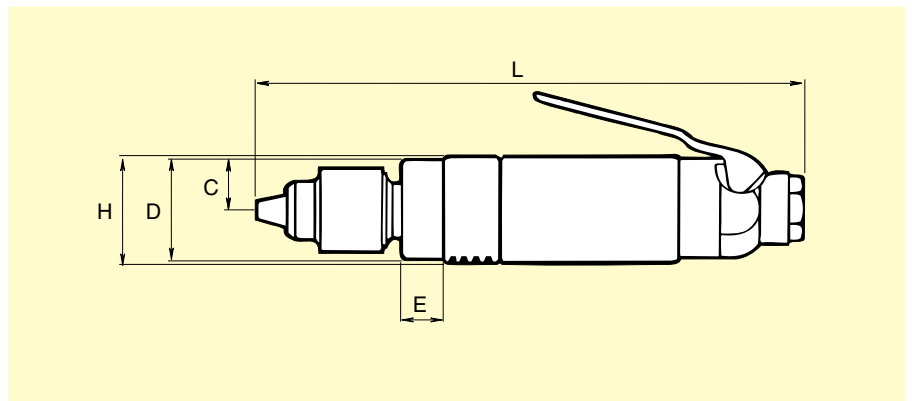

ACCESSORIES INCLUDED

- Chuck, chuck key, hose nipple
- Suspension yoke and chuck guard
- Push button set
- Exhaust hose (-24 models)

OPTIONAL ACCESSORIES

See page 196-197

OPTIONAL ACCESSORIES

Key chucks

Mount	Body diameter mm	Chuck capacity mm	Ordering No.		
			Chuck (key incl)	Key only	Key designation
3/8-24UNF	30	0.0- 6.5	4021 0283 00	4021 0293 00	S1
3/8-24UNF	36	2.0-10.0	4021 0416 00	4021 0449 00	S8
3/8-24UNF	46	2.0-13.0	4021 0289 00	4021 0465 00	S2
JT3	59	3.0-16.0	4021 0423 00	4021 0301 00	S3

Key chuck



Quick chucks

Mount	Chuck dia mm	Chuck capacity mm	Ordering No.
3/8-24UNF	34	0.0- 6.5	4021 0400 00
3/8-24UNF	34	0.0- 8.0	4021 0401 00
3/8-24UNF	36	0.0-10.0	4021 0402 00
3/8-24UNF	36	2.0-13.0	4021 0403 00

Quick chuck



Support handles

For model	Ordering No.
LBB16	4110 1355 92
LBB34/-36	4110 1355 82
LBV34	4110 1355 87
LBB45	4110 1355 84

Support handle



Chuck guards

For model	Max chuck dia mm	Ordering No.
LBB16 ^a	30	4110 1619 04
LBB34/-36 ^b	36	4110 1415 00

^a The guards do not fit 1000 r/min models, 500 r/min and 300 r/min models.

^b The guards do not fit 700 r/min models.

Chuck guard



Silencer sets

For model	Ordering No.
LBB34 H	Exhaust pipe away set 4210 2052 00
LBB45	External silencer 4112 0863 80

Silencer set



OPTIONAL ACCESSORIES

Collet chuck and collets

Designation	Capacity		Ordering No.
	mm	in	
Collet	3		4150 0081 00
	6		4150 0075 00
	8	5/16	4150 0074 00
		1/8	4150 0082 00
		5/32	4150 0648 00
		3/16	4150 0649 00
		1/4	4150 0076 00
	Collet holder		
Collet nut			4150 0760 00

Collet chuck and collets



Flex connect

For model	Ordering No.
LBB16	4110 1601 80

Flex connect



Spot suction attachment

For model	Hose size in	Spot suction kit ^a Ordering No.	Hose kit Ordering No.
LBB16	1 1/4	4110 1715 80	4112 1227 00
LBB34/-36	1 1/4	4110 1716 80	4112 1227 00

^a Spare part, nose piece kit, Ordering No. 4110 1700 90.
Other standard sizes of front nozzle available.

Spot suction attachment



Power feed arm for extra feed force – LBB36 H005

	Ordering No.
Adapter piece (SR295), lever arm (SR201), chain (SR202) and No. 2 Morse socket (SR206)	4110 1416 80
Two extension pieces (SR204-1 and SR204-2), 370 and 750 mm long	4110 1417 80
No. 2 Morse socket	4110 1416 01

Power feed arm



OPTIONAL ACCESSORIES – LBB45

Designation	Ordering No.
Feed screw	4110 0976 80
No. 2 Morse socket	4130 1080 00
Ratchet wrench for feed screw	4130 2000 00
Breast plate	4110 0974 80
Silencer set	4112 0863 80

SERVICE KITS



LBB16	4081 0271 90
LGB24	4081 0005 90
LBB/LGB/LBV34	4081 0035 90
LBB36	4081 0194 90
LBB45	4081 0139 90

ANGLE DRILLS

The perfect drill for cramped spaces

The angle drills are available in versions with 30°, 90° and 360° angle heads and are designed for drilling in confined and awkward spaces.

Just like other Atlas Copco hand drills, they are based on motors from the 25-, 34-, and 36-series.

The angle drills are operated with a lever throttle. The series feature:

- Low noise level.
- Low air consumption.
- Side exhaust/rear exhaust.
- Lubrication-free design.
- Collet chuck or threaded spindle.
- Multiple lever options.



LBV11	110W (0.16 hp)
LBV25 -30/32,-90/92,-91/93	210W (0.3 hp) ^a
LBV34	400W (0.6 hp)
LBV36 -30,-90/92,-91/93	510W (0.73 hp)

^a Maximum power.

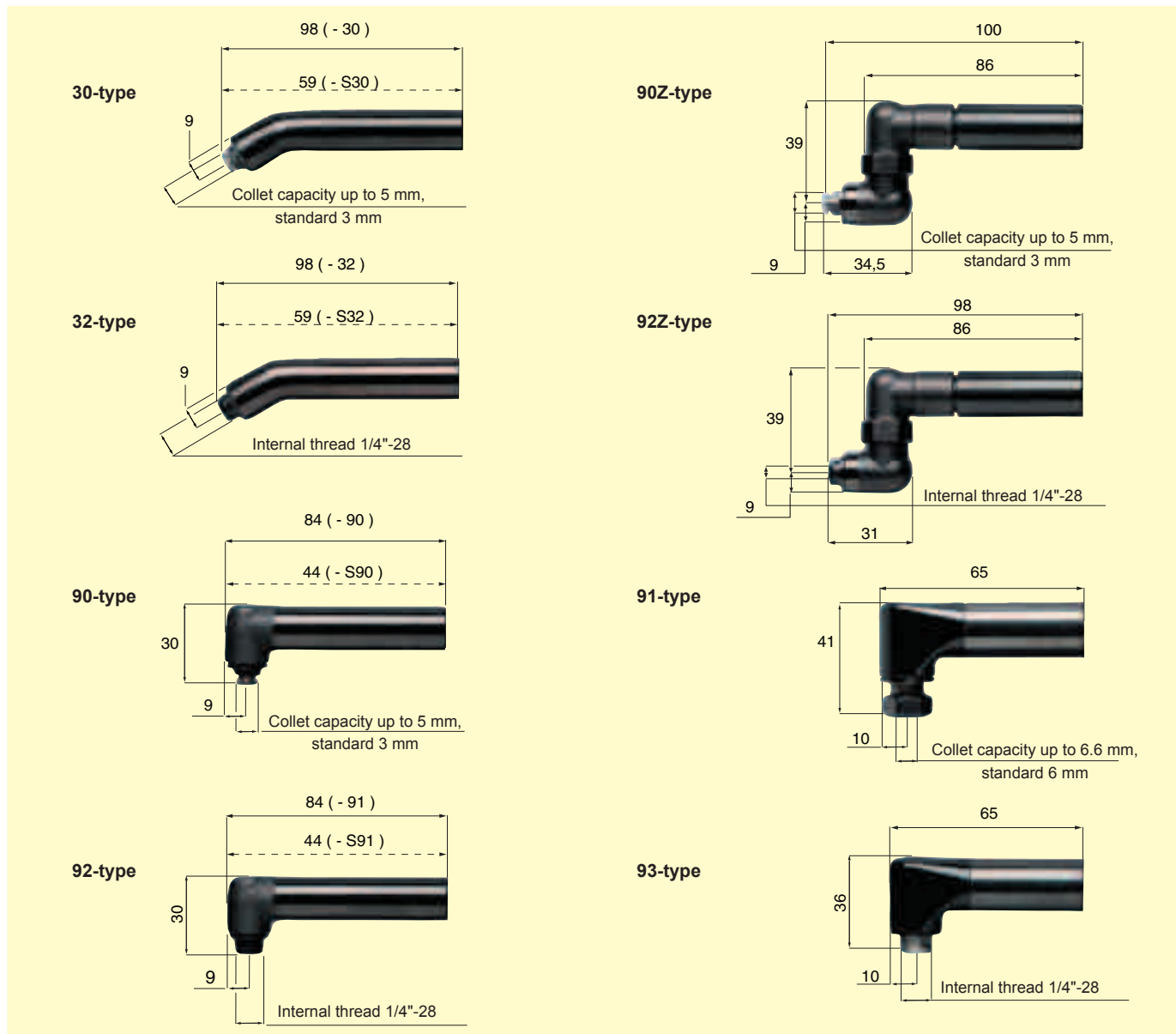

ANGLE DRILLS

Model	Free speed r/min	Setting range rpm	Collet or chuck capacity mm	Weight		Air consumption at free speed		Hose dimension		Air inlet thread BSP	Sound level at free speed dB(A)	Ordering No.
				kg	lb	l/s	cfm	mm	in			
30° angle head – Collet chuck models – small angle head												
LBV11 S027-S30	2700	–	5.0	0.5	1.1	3.2	6.8	5.0	1/8	1/4	71	8421 0108 70
LBV25 EA032-S30	3200	1500-4000	5.0	0.6	1.3	3.2	6.8	6.3	1/4	1/4	70	8421 0218 00*
LBV25 EA032-30	3200	1500-4000	5.0	0.7	1.5	3.2	6.8	6.3	1/4	1/4	70	8421 0218 01*
LBV25 EA032-S32	3200	1500-4000	^c	0.6	1.3	3.2	6.8	6.3	1/4	1/4	70	8421 0218 02
LBV25 EA032-32	3200	1500-4000	^c	0.7	1.5	3.2	6.8	6.3	1/4	1/4	70	8421 0218 03
LBV36 S030-30 ^d	3000	–	5.0	1.0	2.2	17.0	36.0	10.0	3/8	1/4	82	8421 0414 70
LBV36 S030-S30 ^d	3000	–	5.0	0.9	2.0	17.0	36.0	10.0	3/8	1/4	82	8421 0414 71
LBV36 S045-30 ^d	4500	–	5.0	1.0	2.2	17.0	36.0	10.0	3/8	1/4	82	8421 0414 72*
LBV36 S045-S30 ^d	4500	–	5.0	0.9	2.0	17.0	36.0	10.0	3/8	1/4	82	8421 0414 73
90° angle head												
LBV11 S025-S90	2500	–	5.0	0.5	1.1	3.2	6.8	5.0	1/8	1/4	71	8421 0109 79*
LBV25 EA032-S90	3200	1500-4000	5.0	0.6	1.3	3.2	6.8	6.3	1/4	1/4	70	8421 0218 04*
LBV25 EA032-90	3200	1500-4000	5.0	0.7	1.5	3.2	6.8	6.3	1/4	1/4	70	8421 0218 05*
LBV25 EA032-S92	3200	1500-4000	^c	0.6	1.3	3.2	6.8	6.3	1/4	1/4	70	8421 0218 06
LBV25 EA032-92	3200	1500-4000	^c	0.7	1.5	3.2	6.8	6.3	1/4	1/4	70	8421 0218 07*
LBV36 S030-90 ^d	3000	–	5.0	1.0	2.2	17.0	36.0	10.0	3/8	1/4	82	8421 0414 60*
LBV36 S030-S90 ^d	3000	–	5.0	0.9	2.0	17.0	36.0	10.0	3/8	1/4	82	8421 0414 61
LBV36 S045-90 ^d	4500	–	5.0	1.0	2.2	17.0	36.0	10.0	3/8	1/4	82	8421 0414 62*
LBV36 S045-S90 ^d	4500	–	5.0	0.9	2.0	17.0	36.0	10.0	3/8	1/4	82	8421 0414 63
LBV36 S030-92 ^d	3000	–	^c	1.0	2.2	17.0	36.0	10.0	3/8	1/4	82	8421 0414 64
LBV36 S030-S92 ^d	3000	–	^c	0.9	2.0	17.0	36.0	10.0	3/8	1/4	82	8421 0414 65
LBV36 S045-92 ^d	4500	–	^c	1.0	2.2	17.0	36.0	10.0	3/8	1/4	82	8421 0414 66
LBV36 S045-S92 ^d	4500	–	^c	0.9	2.0	17.0	36.0	10.0	3/8	1/4	82	8421 0414 67
360° angle head												
LBV25 EA032-90Z	3200	1500-4000	5.0	0.7	1.5	3.2	6.8	6.3	1/4	1/4	70	8421 0218 08*
LBV25 EA032-92Z	3200	1500-4000	^c	0.7	1.5	3.2	6.8	6.3	1/4	1/4	70	8421 0218 09
90° angle head – Collet chuck models – large angle head												
LBV25 EA045-91	4500	1500-4500	6.6	0.8	1.7	5.4	11.4	6.3	1/4	1/4	73	8421 0218 10*
LBV25 EA020-91	2000	800-2000	6.6	0.8	1.7	5.4	11.4	6.3	1/4	1/4	72	8421 0218 11*
LBV25 EA010-91	1000	500-1000	6.6	0.9	2.0	5.4	11.4	6.3	1/4	1/4	71	8421 0218 12
LBV25 EA045-93	4500	1500-4500	^c	0.8	1.7	5.4	11.4	6.3	1/4	1/4	73	8421 0218 13
LBV25 EA020-93	2000	800-2000	^c	0.8	1.7	5.4	11.4	6.3	1/4	1/4	72	8421 0218 14*
LBV25 EA010-93	1000	500-1000	^c	0.9	2.0	5.4	11.4	6.3	1/4	1/4	71	8421 0218 15
LBV25 EA005-91	500	200-500	6.6	0.9	2.0	5.4	11.4	6.3	1/4	1/4	72	8421 0218 84
LBV25 EA005-93	500	200-500	^c	0.9	2.0	5.4	11.4	6.3	1/4	1/4	72	8421 0218 99
LBV36 S030-91 ^d	3000	–	6.6	1.0	2.2	17.0	36.0	10.0	3/8	1/4	82	8421 0414 50*
LBV36 S060-91 ^d	6000	–	6.6	1.0	2.2	17.0	36.0	10.0	3/8	1/4	82	8421 0414 51*
LBV36 S030-93 ^d	3000	–	^c	1.0	2.2	17.0	36.0	10.0	3/8	1/4	82	8421 0414 52
LBV36 S060-93 ^d	6000	–	^c	1.0	2.2	17.0	36.0	10.0	3/8	1/4	82	8421 0414 53
90° angle head – Key chuck models												
LBV25 EA020	2000	800-2000	6.5 ^a	0.8	1.7	5.4	11.4	6.3	1/4	1/4	72	8421 0218 60*
LBV34 S040	4000	–	6.5 ^a	1.5	3.3	7.5	15.9	10.0	3/8	1/4	88	8421 0309 46 ^{*b}
LBV34 S010	1000	–	10.0 ^a	2.0	4.4	7.5	15.9	10.0	3/8	1/4	88	8421 0309 12 ^{*b}
LBV34 S005	500	–	13.0 ^a	2.1	4.6	7.5	15.9	10.0	3/8	1/4	87	8421 0309 04 ^{*b}

^a Spindle thread, male 3/8"-24 UNF.

* Available directly from stock.

^b Side exhaust.

^c Internal thread 1/4"-28.

^d Short lever as standard.

ACCESSORIES INCLUDED

Collet or chuck with key

Push button set

Hose nipple

3 mm collet (5.0 collet capacity head)

6 mm collet (6.6 collet capacity head)

OPTIONAL ACCESSORIES

Page 200-201

OPTIONAL ACCESSORIES

Angle drill dimensions – Drilling capacity

Model	Angle head mm					Drilling capacity mm	
	A	B	C	L	H	Mild steel	Aluminum and bronze
LBV11 S027-S30	59	25	18	224	30	4.0	5.0
LBV25 EA032-S30	59	25	18	236	45.5	4.0	5.0
LBV25 EA032-30	98	25	18	275	45.5	4.0	5.0
LBV25 EA032-S32	59	25	18	236	45.5	4.0	5.0
LBV25 EA032-32	98	25	18	275	45.5	4.0	5.0
LBV11 S025-S90	44	30	18	204	30	4.0	5.0
LBV25 EA032-S90	44	30	18	221	45.5	4.0	5.0
LBV25 EA032-90	84	30	18	261	45.5	4.0	5.0
LBV25 EA032-S92	44	30	18	221	45.5	4.0	5.0
LBV25 EA032-92	84	30	18	261	45.5	4.0	5.0
LBV25 EA045-91	65	41	20	239	45.5	3.0	6.6
LBV25 EA045-93	65	36	20	239	45.5	3.0	6.6
LBV25 EA020-91	65	41	20	239	45.5	5.0	6.6
LBV25 EA020-93	65	36	20	239	45.5	5.0	6.6
LBV25 EA010-91	65	41	20	271	45.5	6.6	6.6
LBV25 EA010-93	65	36	20	271	45.5	6.6	6.6
LBV25 EA032-90Z	100	48	18	276	45.5	4.0	5.0
LBV25 EA032-92Z	98	48	18	273	45.5	4.0	5.0
LBV25 EA020	68	82	15	239	45.5	5.0	6.5
LBV34 S045	92	97	20	255	43	3.0	6.5
LBV34 S010	92	114	20	290	43	10.0	10.0
LBV34 S005	92	120	20	290	43	13.0	13.0
LBV36 S030-91	92	41	10	252	43	4.0	6.6
LBV36 S060-91	92	41	10	252	43	2.0	6.6
LBV36 S030-93	92	36	10	252	43	4.0	6.6
LBV36 S060-93	92	36	10	252	43	2.0	6.6
LBV36 S030-30	122	26	9	281	43	4.0	5.0
LBV36 S030S-30	82	26	9	241	43	4.0	5.0
LBV36 S045-30	122	26	9	281	43	3.0	5.0
LBV36 S045S-30	82	26	9	241	43	3.0	5.0
LBV36 S030-90	112	30	9	272	43	4.0	5.0
LBV36 S030S-90	72	30	9	232	43	4.0	5.0
LBV36 S045-90	112	30	9	272	43	3.0	5.0
LBV36 S045S-90	72	30	9	232	43	3.0	5.0
LBV36 S030-92	112	30	9	272	43	4.0	5.0
LBV36 S030S-92	72	30	9	232	43	4.0	5.0

Angle head dimensions

LBV11, -25
30°

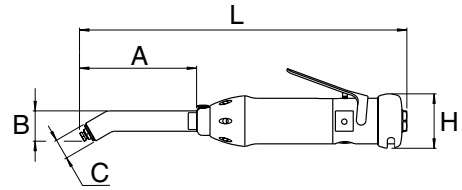

LBV11, -25
90°

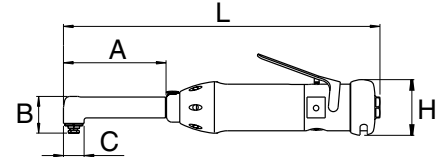

LBV25
360°

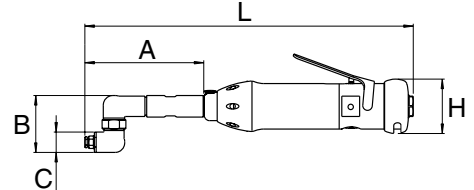

LBV34
90°

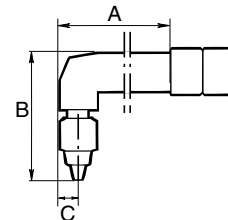

Collets for 5.0 mm capacity head LBV11, LBV25 S032 – (-30, -90, -90Z) and LBV36 (-30, -90)

Capacity mm	Ordering No.	Capacity mm	Ordering No.	Capacity in	Ordering No.
1.0	4110 0438 01	3.4	4110 0438 33	1/16	4110 0438 19
1.5	4110 0438 02	3.5	4110 0438 13	3/32	4110 0438 20
1.8	4110 0438 28	3.6	4110 0438 24	1/8	4110 0438 21
2.0	4110 0438 03	3.7	4110 0438 34	5/32	4110 0438 22
2.1	4110 0438 29	3.8	4110 0438 14	3/16	4110 0438 23
2.2	4110 0438 04	3.9	4110 0438 35		
2.3	4110 0438 30	4.0	4110 0438 15		
2.4	4110 0438 05	4.1	4110 0438 25		
2.5	4110 0438 06	4.2	4110 0438 26		
2.6	4110 0438 07	4.3	4110 0438 36		
2.7	4110 0438 31	4.4	4110 0438 37		
2.8	4110 0438 32	4.5	4110 0438 16		
2.9	4110 0438 08	4.6	4110 0438 38		
3.0	4110 0438 09	4.7	4110 0438 39		
3.1	4110 0438 10	4.8	4110 0438 18		
3.2	4110 0438 11	4.9	4110 0438 40		
3.3	4110 0438 12	5.0	4110 0438 27		

Collets for 5.0 mm (Thread BSF 9/32 -40)

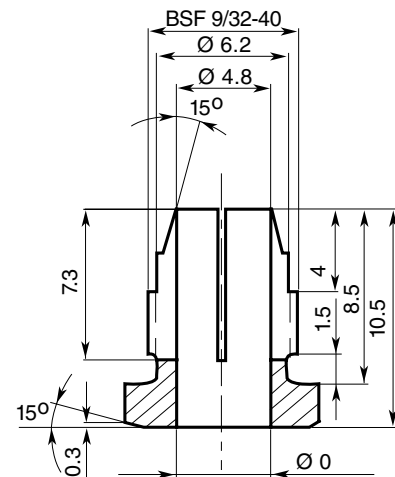

OPTIONAL ACCESSORIES

Collets for 6.6 mm capacity head LBV25 (-91) and LBV36 (-91)

Capacity mm	Ordering No.	Capacity mm	Ordering No.
1.6	4110 1411 01	4.2	4110 1411 14
1.8	4110 1411 02	4.4	4110 1411 15
2.0	4110 1411 03	4.6	4110 1411 16
2.2	4110 1411 04	4.8	4110 1411 17
2.4	4110 1411 05	5.0	4110 1411 18
2.6	4110 1411 06	5.2	4110 1411 19
2.8	4110 1411 07	5.4	4110 1411 20
3.0	4110 1411 08	5.6	4110 1411 21
3.2	4110 1411 09	5.8	4110 1411 22
3.4	4110 1411 10	6.0	4110 1411 23
3.6	4110 1411 11	6.2	4110 1411 24
3.8	4110 1411 12	6.4	4110 1411 25
4.0	4110 1411 13	6.6	4110 1411 26

Collet nut 4110 1410 00, to be ordered separately.

Collets for 6.6 mm

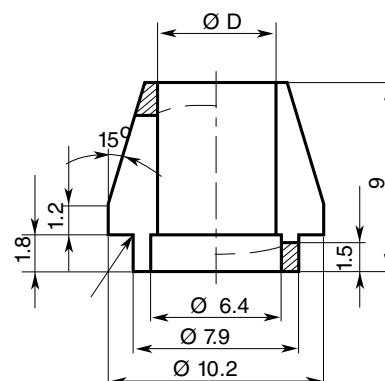

Push button set

For model	Ordering No.
LBB24 S	4110 1427 90
LBV25 EA	4110 1427 90
LBB34 S	4110 1427 91
LBV34 S	4110 1427 91

Push button set



Safety levers

For model		Ordering No.
LBB24 S	Rear exhaust	4210 2306 80
LBB34 S		4150 1035 90
LBV25 EA		4210 2306 81
LBV34 S		4150 1035 90
LBV36		4150 1594 97

Safety lever



Short levers

For model	Ordering No.
LBV25	4210 2306 04
LBV36	4110 1581 01

Short lever



SERVICE KITS

LBB/LGB/LBV24	4081 0005 90
LBV25	4081 0272 90
LBB/LGB/LBV34	4081 0035 90
LBV36 (30, 90/92)	4081 0263 90
LBV36 (91/93)	4081 0251 90

TAPPERS

Atlas Copco tappers are designed for tapping and thread cleaning operations with thread taps. As standard, the tools are fitted with a tap chuck.

- **Comfortable and effective** – The ergonomic design of the handle gives you a comfortable grip and maximum performance.
- **Higher productivity** – Thanks to the double speed when you withdraw the machine.
- **Low noise level** – Rearward-directed exhaust gives a lower noise level.
- **Lubrication-free.**
- **Quick change system** – Equip your old tool or order a new one with this system. Various tap holders can be used to change a broken tap or to change to a different tap size.
- **Lower cost** – The efficient air motor together with interchangeable components from our standard drills cut your costs.



Model	Free speed		Tapping capacity mm	Weight		Hose dimension		Air inlet thread BSP	Air consumption		With chuck		Without chuck	
	Forward r/min	Reverse r/min		kg	lb	mm	in		l/s	cfm	Ordering No.	Model	Ordering No.	
Pistol-grip tappers with air supply through handle														
LGB24 H007	700	1400	6	1.1	2.4	6.3	1/4	1/4	5.5	11.5	8421 0210 67*	-U	8421 0210 69	
LGB24 H007Q ^a	700	1400	6	1.1	2.4	6.3	1/4	1/4	5.5	11.5	8421 0210 75*	-	-	
LGB34 H007	700	1400	10	1.8	4.0	10.0	3/8	1/4	7.5	15.9	8421 0311 66*	-U	8421 0311 68*	
LGB34 H007Q ^a	700	1400	10	1.8	4.0	10.0	3/8	1/4	7.5	15.9	8421 0311 76*	-	-	
LGB36 H007Q ^a	700	1400	12	2.0	4.4	10.0	3/8	3/8	16.5	34.9	8421 0411 00*	-	-	
Pistol-grip tappers with air supply on top														
LGB24 HF007	700	1400	6	1.2	2.6	6.3	1/4	1/4	6.0	12.7	8421 0210 80	-	-	
LGB24 HF007Q ^a	700	1400	10	1.2	2.6	6.3	1/4	1/4	6.0	12.7	8421 0210 82	-	-	
Straight tappers														
LGB24 S007	700	1400	6	1.1	2.4	6.3	1/4	1/4	5.5	11.6	8421 0210 71	-U	8421 0210 73	
LGB34 S007	700	1400	10	1.8	4.0	10.0	3/8	1/4	7.5	15.9	8421 0311 72	-U	8421 0311 74	

^a Quick change system.

Taper: Jacob 1

* Available directly from stock.

DIMENSIONS LGB (mm)

Model	L	H	C
LGB24 H007	260	154	18
LGB34 H007	300	156	20
LGB24 HF007	235	200	20
LGB24 S007	253	38	19
LGB34 S007	293	43	21
LGB36 H007	335	157	20

ACCESSORIES INCLUDED

Non Quick change system

LGB24 Chuck complete with collet
4.5-6.5 mm 4021 0410 00

LGB34 Chuck complete with collet
6.4-10 mm 4021 0469 00

Quick change system

Chuck plus one tap holder with collet for M6 shank Ø 6.3 mm.

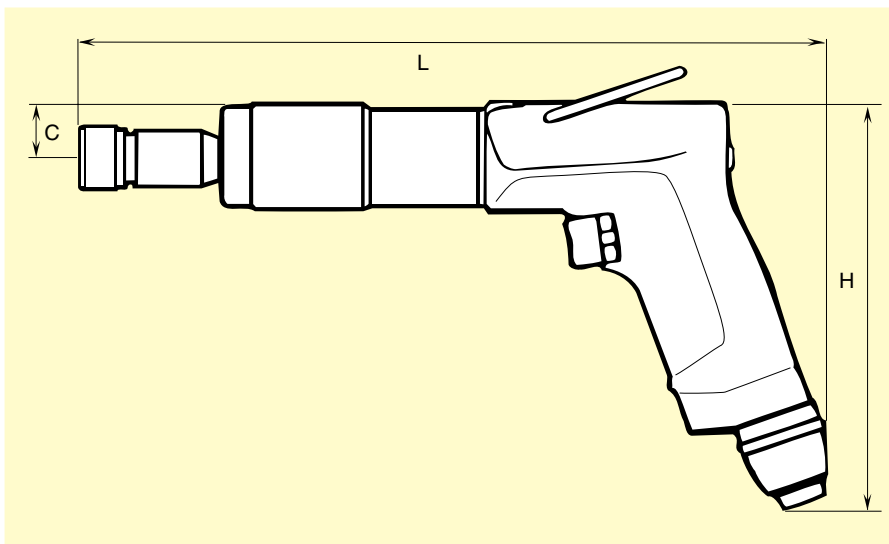

OPTIONAL ACCESSORIES

Collets for non Quick change system

Model	Capacity mm	Ordering No.
LGB24	2.5- 4.5	4021 0412 00
	4.5- 6.5	4021 0413 00
LGB34	3.5- 6.5	4021 0337 00
	4.5- 8.0	4021 0336 00
	6.4-10.0	4021 0456 00

Collets for Quick change system

Collets for tap size mm	Shank dia mm	Ordering No.
M2.2/M2.5	2.8	4021 0414 01
M3	3.15	4021 0414 02
M3.5	3.5	4021 0414 03
M4	4.0	4021 0414 04
M4.5	4.5	4021 0414 05
M5	5.0	4021 0414 06
M5.5	5.6	4021 0414 07
M6	6.3	4021 0414 08
M6 (DIN)	6.0	4021 0414 13
M7	7.1	4021 0414 09
M8/M11	8.0	4021 0414 10
M9/M12	9.0	4021 0414 11
M10	10.0	4021 0414 12



SERVICE KITS

LGB24	4081 0005 90
LGB34	4021 0035 90
LGB36	4081 0194 90

Completing existing equipment with Quick change system

Accessories	Length mm	Ordering No.
Quick change chuck	47	4021 0406 90
Tap holder	58	4021 0408 00



SCREW-FEED DRILLS

Atlas Copco screw-feed drills are ideal for heavy-duty drilling operations requiring high feed forces. You can also use these drills for reaming and tube-rolling.

- **Reliable** – They have a simple and reliable design.
- **Constant speed** – The speed governor keeps the drilling speed constant and reduces air consumption as power is reduced.
- **Safer** – The safety catch prevents accidental starting. The throttle is also self-closing.

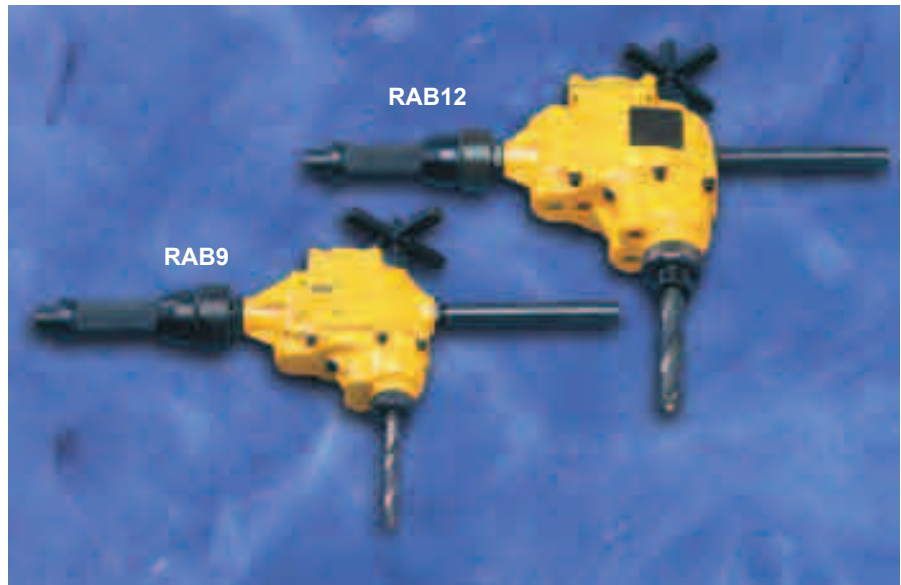

Model	Forward	Reverse
RAB9	0.85 kW (1.14 hp)	0.55 kW (0.74 hp)
RAB12	1.5 kW (2.0 hp)	1.1 kW (1.5 hp)

Model	Free speed r/min	Capacity				Morse taper No.	Length feed mm	Height		Weight kg lb	Hose dimension		Air consumption max output		Distance centre to side mm	Air inlet thread BSP	Ordering No.
		Drill- ing mm	Ream- ing mm	Tapp- ing mm	mm			in	mm		in	l/s	cfm				
Reversible screw-feed drills																	
RAB9 VR006	600	23	23	12	2	75	265	10.4	9.5	20.9	13	1/2	23	49	40	1/2	8421 5109 45*
RAB9 VR003	300	23	23	16	2	75	265	10.4	9.5	20.9	13	1/2	22	47	40	1/2	8421 5109 37*
RAB12 L450	475	32	32	24	3	90	340	13.4	12.9	28.4	16	5/8	32	68	50	1/2	8421 5112 24*
RAB12 L250	240	51	40	30	4	90	385	13.2	14.9	32.8	16	5/8	33	70	50	1/2	8421 5112 16*
RAB12 L150	140	51	40	32	4	90	385	15.2	14.9	32.8	16	5/8	30	64	50	1/2	8421 5112 08*

* Available directly from stock.

ACCESSORIES INCLUDED

Hose nipple

OPTIONAL ACCESSORIES

Breast plate



Square drive adapter



Model	Ordering No.
RAB9	4110 0974 82
RAB12	4110 0974 83

Morse taper No.	Square drive in	Ordering No.
3	1	4021 0394 00
4	1	4021 0395 00